

(12) INTERNATIONAL APPLICATION PUBLISHED UNDER THE PATENT COOPERATION TREATY (PCT)

(19) World Intellectual Property Organization
International Bureau



(43) International Publication Date
25 May 2001 (25.05.2001)

PCT

(10) International Publication Number
WO 01/36075 A1

- (51) International Patent Classification⁷: B01D 65/02, 65/06, 63/02, 63/04, C02F 3/06
- (21) International Application Number: PCT/CA00/01354
- (22) International Filing Date:
15 November 2000 (15.11.2000)
- (25) Filing Language: English
- (26) Publication Language: English
- (30) Priority Data:
2,290,053 18 November 1999 (18.11.1999) CA
PCT/CA99/01113
18 November 1999 (18.11.1999) CA
09/505,718 17 February 2000 (17.02.2000) US
2,308,230 5 May 2000 (05.05.2000) CA
09/565,032 5 May 2000 (05.05.2000) US
- (71) Applicant (for all designated States except US): ZENON ENVIRONMENTAL INC. [CA/CA]; 3239 Dundas Street West, Oakville, Ontario L6N 4B2 (CA).
- (72) Inventors; and
(75) Inventors/Applicants (for US only): JANSON, Arnold [CA/CA]; 343 Rankin Drive, Burlington, Ontario L7N 2B2 (CA). ADAMS, Nicholas [CA/CA]; 37 Kipling Road, Hamilton, Ontario L8S 3X2 (CA). CADERA, Jason [CA/CA]; 25 Camm Crescent, Guelph, Ontario N1L 1K2 (CA). COTE, Pierre [CA/CA]; 26 Taly-Ho Drive, Dundas, Ontario L9H 3M6 (CA). PEDERSEN, Steven, Kristian [CA/CA]; 498 Rothesay Place, Burlington, Ontario L7N 3E2 (CA).
- (74) Agent: BERESKIN & PARR; 40 King Street West, 40th floor, Toronto, Ontario M5H 3Y2 (CA).
- (81) Designated States (national): AE, AG, AL, AM, AT, AU, AZ, BA, BB, BG, BR, BY, BZ, CA, CH, CN, CR, CU, CZ,

[Continued on next page]

(54) Title: IMMERSED MEMBRANE FILTRATION SYSTEM AND OVERFLOW PROCESS

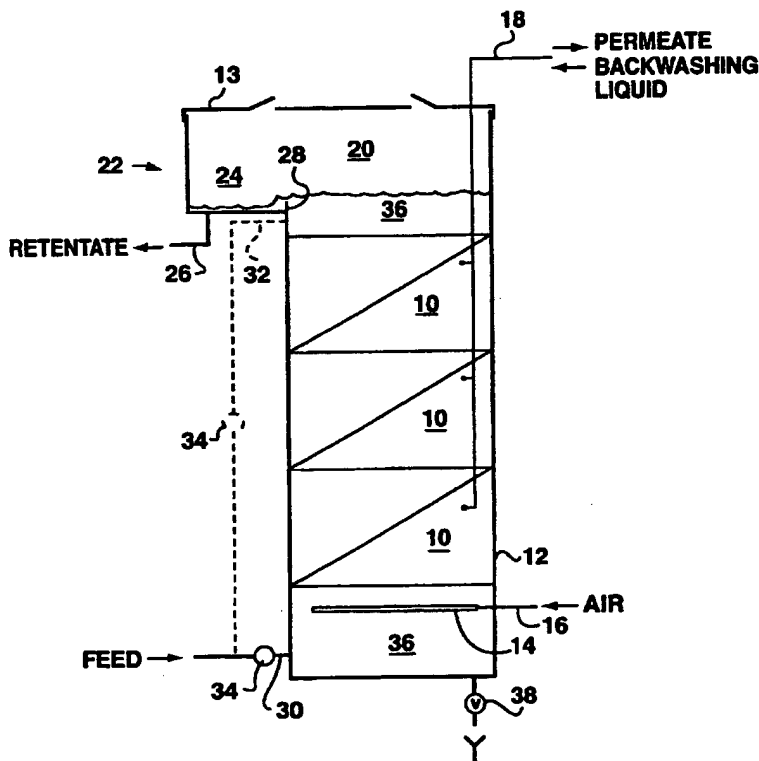

(57) Abstract: Modules of ultrafiltration or microfiltration membranes are arranged in a tank open to the atmosphere to substantially cover the cross sectional area of the tank. A filtration cycle has permeation steps and deconcentration steps. During permeation, supply of feed substantially equals feed removed and little if any aeration is used. During deconcentration, aeration with scouring bubbles is provided with one or both of backwashing and feed flushing. In feed flushing, feed water is supplied to the tank from below the modules. Excess tank water created during deconcentration flows generally upwards through the modules and out through a retentate outlet or overflow at the top of the tank.



WO 01/36075 A1



DE, DK, DM, DZ, EE, ES, FI, GB, GD, GE, GH, GM, HR, HU, ID, IL, IN, IS, JP, KE, KG, KP, KR, KZ, LC, LK, LR, LS, LT, LU, LV, MA, MD, MG, MK, MN, MW, MX, MZ, NO, NZ, PL, PT, RO, RU, SD, SE, SG, SI, SK, SL, TJ, TM, TR, TT, TZ, UA, UG, US, UZ, VN, YU, ZA, ZW.

Published:

- *With international search report.*
- *Before the expiration of the time limit for amending the claims and to be republished in the event of receipt of amendments.*

(84) **Designated States (regional):** ARIPO patent (GH, GM, KE, LS, MW, MZ, SD, SL, SZ, TZ, UG, ZW), Eurasian patent (AM, AZ, BY, KG, KZ, MD, RU, TJ, TM), European patent (AT, BE, CH, CY, DE, DK, ES, FI, FR, GB, GR, IE, IT, LU, MC, NL, PT, SE, TR), OAPI patent (BF, BJ, CF, CG, CI, CM, GA, GN, GW, ML, MR, NE, SN, TD, TG).

For two-letter codes and other abbreviations, refer to the "Guidance Notes on Codes and Abbreviations" appearing at the beginning of each regular issue of the PCT Gazette.

Title: Immersed Membrane Filtration System and Overflow Process**FIELD OF THE INVENTION**

5 This invention relates to a filtration system using immersed suction driven filtering membranes to filter water, for example, to filter surface water to produce potable water, and to a method of operating such a system.

BACKGROUND OF THE INVENTION

10

 A prior art immersed membrane water filtration system is shown in Figure 1. An open tank (a) holds a membrane module (b) immersed in tank water (c). Feed water to be filtered flows into the tank, typically continuously. Suction on an inner surface of the membranes in the
15 membrane module (b) draws filtered permeate through the membrane wall. Solids are rejected by the membranes and accumulate in the tank water (c). Solids rich retentate is continuously or periodically drained from the tank.

20

 The membrane module (b) is cleaned in part by backwashing and aeration. In backwashing, a backwashing liquid (typically permeate or permeate with a chemical additive) is pumped into the inner spaces of the membranes and flows into the tank water (c). In aeration, air bubbles are created at an aerator (d) mounted below the membrane module (c). The air
25 bubbles agitate and scour the membranes and create an air lift effect. The air lift effect moves tank water (c) in a recirculation pattern (e) upwards through the membrane module (b) and in a downcomer (f) through spaces between the perimeter of the module (b) and the sides of the tank (a). The tank water (c) flowing in the recirculation pattern (e) further physically
30 cleans the membranes and disperses solids rich water from near the membrane module (b).

SUMMARY OF THE INVENTION

It is an object of the present invention to improve on the prior art. This object is met by the combination of features, steps or both found in the independent claims, the dependent claims disclosing further advantageous
5 embodiments of the invention. The following summary may not describe all necessary features of the invention which may reside in a sub-combination of the following features or in a combination with features described in other parts of this document.

10

In various aspects of the invention, a filtration system having immersed suction driven filtering membranes is used to filter water containing low concentrations of suspended solids, for example, to filter surface water to produce potable water. A process is provided for operating
15 such a system.

Membrane modules are arranged in a tank open to the atmosphere and fill most of its horizontal cross sectional area. An upper portion of the tank encloses a volume directly above the modules. This upper portion of
20 the tank is provided with a retentate outlet from the tank. Tank water that is not withdrawn as permeate flows out of the tank through the retentate outlet.

Permeate is withdrawn by suction on an inner surface of the
25 membranes, preferably at a flux between 10 and 60 L/m²/h, more preferably between 20 and 40 L/m²/h. Feed water is added to the tank at a rate that substantially equals the rate at which permeate is withdrawn. Thus during permeation little if any tank water flows out of the outlet and the level of the tank water remains above the membranes.

30

Permeation is stopped periodically for a deconcentration step. During the deconcentration step the membranes are backwashed, feed flow is

provided from below the modules or both. Tank water rises through the modules, the water level in the tank rises and tank water containing solids (then called retentate) flows out of the retentate outlet to deconcentrate the tank water. Aeration with scouring bubbles is provided during the
5 deconcentration step.

BRIEF DESCRIPTION OF THE DRAWINGS

Figure 1 is a schematic representation of a prior art filtration system.

10 Figure 2 is a schematic representation of a filtering reactor made in accordance with a preferred embodiment of the present invention.

Figure 3 is a plan view of a filtering reactor made in accordance with a preferred embodiment of the present invention.

15 DETAILED DESCRIPTION OF EMBODIMENTS

Referring to Figure 2, three membrane modules 10 are stacked on top of each other in a tank 12. The tank 12 is open to the atmosphere although it may be covered with a vented lid 13. The membrane modules 10 may
20 contain flat sheet or hollow fibre membranes with pore sizes in the microfiltration or ultrafiltration range, preferably between 0.003 and 10 microns and more preferably between 0.01 and 1.0 microns. An inner surface of the membranes is connected to one or more headers. An aerator 14 is mounted below the membrane modules 10. The aerator 14 is
25 connected to an air supply pipe 14 in turn connected to a supply of air, nitrogen or other suitable gas. The membrane modules 10 include, within their horizontal cross-sectional area, channels for water and air bubbles to flow vertically through the membrane modules 10 to agitate or scour the membranes. When membrane modules 10 are stacked on top of each other,
30 they are aligned such that water can flow vertically through the stack.

Preferably, the membrane modules 10 contain hollow fibre membranes oriented horizontally and mounted in a slightly slackened state between pairs of horizontally spaced, vertically extending headers. One example is formed of several elements placed side-by-side, each element 5 having a large number of fibres of between 0.2 and 1.0 mm outside diameter and between 0.2 m and 1.0 m in length (the shorter length used for the smaller diameter fibres and the longer length used for larger diameter fibres) potted at either end in a header but with permeate withdrawn from only one header. The elements may be separated by impervious vertical 10 plates. Such modules can provide 500 to 1500 m² of membrane surface area for each m² of horizontal cross-sectional area of a large municipal or commercial tank and there is minimal channeling or dead zones when tank water flows through the modules.

15 The membrane modules 10 are sized and positioned to fill most of the horizontal cross-sectional area of the tank 12 leaving room only for necessary fittings and other apparatus and maintenance or set-up procedures. Space is not provided for downcomers outside the perimeter of the modules 10 and baffles are provided if necessary to block flow through 20 any space left for fittings etc. or otherwise outside the perimeter of the membrane modules 10. Preferably more than 90%, more preferably substantially all, of the horizontal cross-sectional area of the tank 12 is filled with membrane modules 10.

25 A permeate pipe 18 connects the headers of the membrane modules 10 to means for permeating by suction on the inner surfaces of the membranes and backwashing means. Such means are known in the art and allow the permeate pipe 18 to be used to either withdraw permeate from the tank 12 or to flow a backwashing liquid (typically permeate or permeate 30 mixed with a chemical) in a reverse direction through the membranes and into the tank 12 in which the backwashing liquid becomes part of tank water 36.

An upper portion 20 of the tank 12 is provided with a retentate outlet 22 having an overflow area 24 connected to a drain pipe 26 to remove retentate from the tank 12. Retentate outlet 22 preferably incorporates an overflow or weir 28 which helps foam produced by aeration (otherwise a cleanliness, safety or volatile chemical release problem) to flow into the overflow area 24. The retentate outlet 22 preferably also has sufficient capacity to release expected flows of retentate quickly to reduce the required free board of the tank 12.

10

Feed water enters the tank 12 through a first inlet 30 or a second inlet 32 as determined by feed valves 34. Once in the tank 12, feed water may be called tank water 36 which flows generally upwards or downwards through the membrane modules 10.

15

A filtration cycle has a permeation step followed by a deconcentration step and is repeated many times between more intensive maintenance or recovery cleaning procedures. The permeation step typically lasts for about 15 to 60 minutes, preferably 20 to 40 minutes and is carried out in the absence of aeration. Permeate flux is preferably between 10 and 60 L/m²/h, more preferably between 20 and 40 L/m²/h, wherein the surface area of hollow fibre membranes is based on the outside diameter of the membranes.

25

During permeation, feed water is added to the tank 12 from one of the inlets 30, 32 at substantially the rate at which permeate is withdrawn. Tank water 36 flows through the membrane modules 10 to generally replace permeate as it is withdrawn from the tank 12. Thus during permeation little if any tank water 36 flows out of the retentate outlet 22 and the level of the tank water 36 remains above the membranes. If the membrane module 10 acts to some extent like a media filter (as will some membrane modules 10 of tightly packed horizontally oriented hollow fibre membranes), feed

30

preferably enters the tank 12 through the second inlet 32. In this way, solids in some feed waters are preferentially deposited in the upper membrane module 10, closer to the retentate outlet 22 and where the upward velocity of the tank water 36 during a deconcentration step will be the greatest, as will be explained below. This set-up is also useful in retrofitting sand filters which are typically set up to receive feed from the top and to backwash from below. For other membrane modules 10, installations or feed waters, the first inlet 30 may be used during permeation.

10 The deconcentration step commences when permeation stops and lasts for about 20 to 90 seconds, preferably 30 to 60 seconds. During the deconcentration step, scouring bubbles are produced at the aerator 14 and rise through the membrane modules 10. In addition one or both of the steps of backwashing and feed flushing are performed. To flush with feed
15 water, feed enters the tank 12 through the first inlet 30 creating an excess of tank water 36 which rises upwards through the membrane modules 10. The rate of flow of feed water during feed flushing is typically between 0.5 and 2, preferably between 0.7 and 1.5, times the rate of flow of feed water during permeation. With either backwashing or feed flushing, the level of
20 the tank water 36 rises, tank water 36 flows upwards through the membrane modules 10 and tank water 36 containing solids (then called retentate) flows out of the retentate outlet 22 to deconcentrate the tank water 36.

In some cases, the upwards velocity of the tank water 36 may create
25 forces on the membranes that exceed their strength, particularly if strong feed flushing and back washing are performed simultaneously. In these cases, the rate of flow of feed water or backwash liquid or both can be reduced to reduce the upward velocity of the tank water 36. Alternatively, the flow of feed water can be turned off during backwashing and any feed
30 flushing done while there is no backwashing and vice versa. For example, a deconcentration step may involve backwashing preferably with aeration but without feed flushing for a first part of the deconcentration step and feed

flushing preferably with aeration but without backwashing for a second part of the deconcentration step. Further alternatively, deconcentration steps involving backwashing preferably with aeration but without feed flushing can be performed in some cycles and deconcentration steps involving feed
5 flushing preferably with aeration but without backwashing can be used in other cycles. Other combinations of the above procedures might also be used.

Aeration is typically performed at the same time as the other steps to
10 reduce the total time of the deconcentration step. Aeration may, however, begin several seconds (approximately the time required for a bubble to rise from the aerator 14 to the surface of the tank water 36) before backwashing or feed flushing. Such aeration in the absence of tank water 36 flow (because no space was left for downcomers) causes turbulence which help
15 loosen some foulants and float some solids to near the top of the tank 12 before retentate starts flowing out the retentate outlet 20.

Aeration during the deconcentration step does not need to overcome suction to dislodge solids from the membranes and is provided at a
20 superficial velocity (m^3/h of air at standard conditions per m^2 of module cross-sectional area) between 25 m/h and 75 m/h . For many if not most feed waters, particularly those feed waters having low turbidity and solids concentrations less than about 500 mg/L , additional aeration is not required. Nevertheless, a smaller amount of aeration may be provided with difficult
25 feed water during permeation to disperse solids from dead zones in a membrane module 10 and homogenize the tank water 36. For this purpose, aeration is provided at a superficial velocity less than 25 m/h or intermittently at the higher rates described above.

30 During the deconcentration step, the feed water or backwashing liquid introduced into the tank 12 creates a flow of tank water 36 upwards through the modules 10. The tank water 36 flowing through the membrane

modules 10 helps remove solids loosened by the scouring bubbles from the membrane modules 10 and also directly acts on the surface of the membranes. The tank water 36 flows most rapidly near the top of the tank 12 which helps reduce preferential fouling of upper membranes when
5 membrane modules 10 are stacked, for example to depths of 2 m or more. Some solids in the tank water 36 may have a settling velocity greater than the velocity of the upflow velocity and will settle. The volume of these solids is small and they may be removed from time to time by partially draining the tank 12 through a supplemental drain 38.

10

Based on a design permeate flux, the required flow of feed water during permeation can be calculated and delivered, typically by adjusting a feed pump or feed valve. The frequency and intensity of deconcentration events is then selected to achieve a desired loss in membrane permeability
15 over time. If flux during permeation is kept below about 60 L/m²/h, preferably less than 40 L/m²/h, the inventors have found that surprising little fouling occurs and the periodic deconcentration events are usually sufficient. More surprisingly, the energy cost savings produced by operating at low flux and low aeration more than offsets the cost of filling the tank 12
20 with membrane modules 10. Despite the low flux (compared to a more typical flux of 50 to 100 L/m²/h), high tank velocities (flux of permeate in m³/h divided by tank horizontal cross sectional area in m²) are achieved which compare favourably with sand filtration. Further, resulting recovery rates are generally adequate for single stage filtration and are typically
25 adequate for the first stage of two stage filtration (wherein the retentate is re-filtered) even with aggressive deconcentration.

Figure 3 shows a plan view of a larger filtering reactor. A second tank 200 encloses several cassettes 220 each of which may contain a plurality of
30 membrane modules. Open channels 202 are provided between adjacent cassettes 220 to receive tank water overflowing the cassettes 210 as described above. The channels 202 are sloped to drain towards a larger trough 204

which is in turn sloped to drain towards a second outlet 206. The second outlet 206 has an outlet box 208 to temporarily hold the discharged tank water before it flows into a drain pipe 210. As in the embodiment of figure 9, feed water enters the second tank 200 at a point below the cassettes 220, 5 but several second inlets 212 are attached to an inlet header 214 to provide a distributed supply of feed.

It is to be understood that what has been described are preferred embodiments of the invention for example and without limitation to the 10 combination of features necessary for carrying the invention into effect. The invention may be susceptible to certain changes and alternative embodiments without departing from the subject invention, the scope of which is defined in the following claims.

We claim:

1. A process of filtering water comprising the steps of,
 - (a) providing one or more modules of filtering membranes immersed in water in a tank open to the atmosphere;
 - (b) providing a retentate outlet from a portion of the tank above the one or more modules;
 - (c) permeating filtered water by (i) adding a selected volume of feed water to the tank and (ii) withdrawing substantially the selected volume of water through the one or more modules as permeate;
 - (d) periodically stopping permeation to perform a deconcentration step, the deconcentration step further comprising providing scouring bubbles from below the modules and at least one of (I) backwashing or (II) providing a flow of feed water into the tank from below the modules or both (I) and (II); and,
 - (e) flowing excess water containing retained solids out of the retentate outlet during the deconcentration step.
2. The process of claim 1 wherein the modules cover most of the horizontal cross sectional area of the tank.
3. The process of claim 1 wherein the modules cover more than 90% of the horizontal cross sectional area of the tank.
4. The process of claim 1 wherein the modules cover substantially all of the horizontal cross sectional area of the tank.
5. The process of claim 1 wherein aeration is commenced before backwashing.

6. The process of claim 1 wherein the filtering membranes are hollow fibres oriented horizontally.
7. The process of claim 4 wherein the filtering membranes are hollow fibres oriented horizontally.
8. A process of filtering water comprising,
repeating a filtration cycle having
 - (a) a permeation step wherein,
 - (i) feed water enters a tank; and,
 - (ii) a similar volume of permeate is withdrawn from the tank by suction on an inner surface of submerged filtering membranes; and,
 - (b) a deconcentration step wherein,
 - (iii) scouring bubbles rise through the modules;
 - (iv) the membranes are backwashed; and,
 - (v) water containing solids flows upwards through the modules and exits the tank.
9. The process of claim 8 wherein the filtering membranes are hollow fibres oriented horizontally.
10. A filtering reactor comprising,
 - (a) a tank open to the atmosphere;
 - (b) one or more modules of suction driven filtering membranes in the tank for withdrawing a filtered permeate;
 - (c) an inlet to add feed water to the tank from below the one or more modules;
 - (d) a retentate outlet to discharge water containing retained solids from the tank from above the one or more modules; and,
 - (e) an aerator below the one or more modules.

11. The reactor of claim 10 wherein the modules cover most of the horizontal cross sectional area of the tank.
12. The reactor of claim 10 wherein the modules cover more than 90% of the horizontal cross sectional area of the tank.
13. The reactor of claim 10 wherein the modules cover substantially all of the horizontal cross sectional area of the tank.
14. The reactor of claim 10 wherein the retentate outlet incorporates an overflow or weir.
15. The reactor of claim 10 wherein the filtering membranes are hollow fibres oriented horizontally.
16. The reactor of claim 13 wherein the filtering membranes are hollow fibres oriented horizontally.
17. The process of claim 8 wherein feed water is provided from above the modules during permeation.
18. The process of claim 9 wherein feed water is provided from above the modules during permeation.
19. A process of filtering water comprising, repeating a filtration cycle having
 - (a) a permeation step wherein,
 - (i) feed water enters a tank; and,
 - (ii) a similar volume of permeate is withdrawn from the tank by suction on an inner surface of submerged filtering membranes; and,
 - (b) a deconcentration step wherein,
 - (iii) scouring bubbles rise through the modules;

- (iv) feed water flows into the tank from below the modules; and,
- (v) water containing solids flows upwards through the modules and exits the tank.

20. The process of claim 19 wherein the filtering membranes are hollow fibres oriented horizontally.

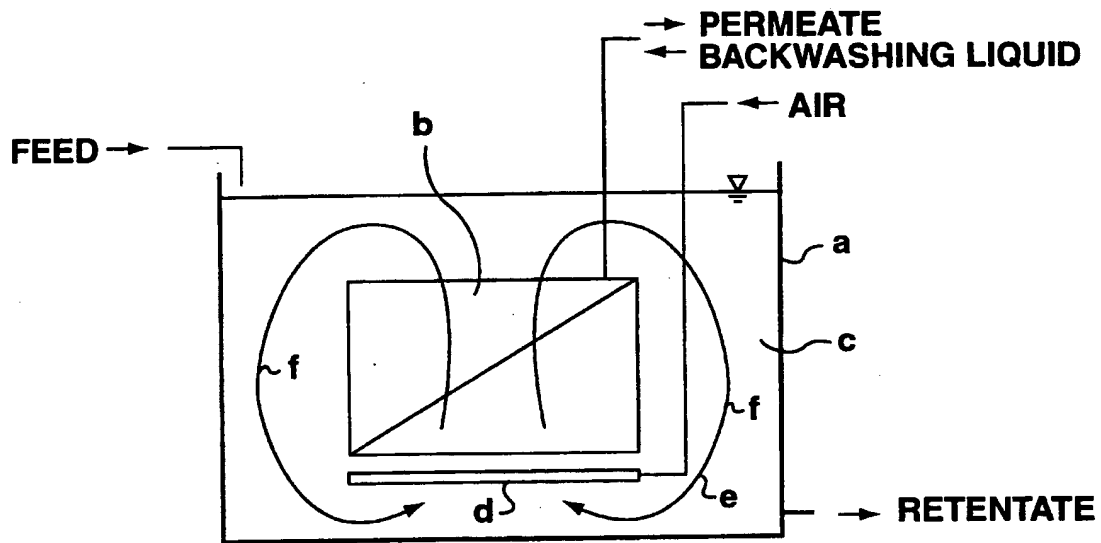

FIG.1 PRIOR ART

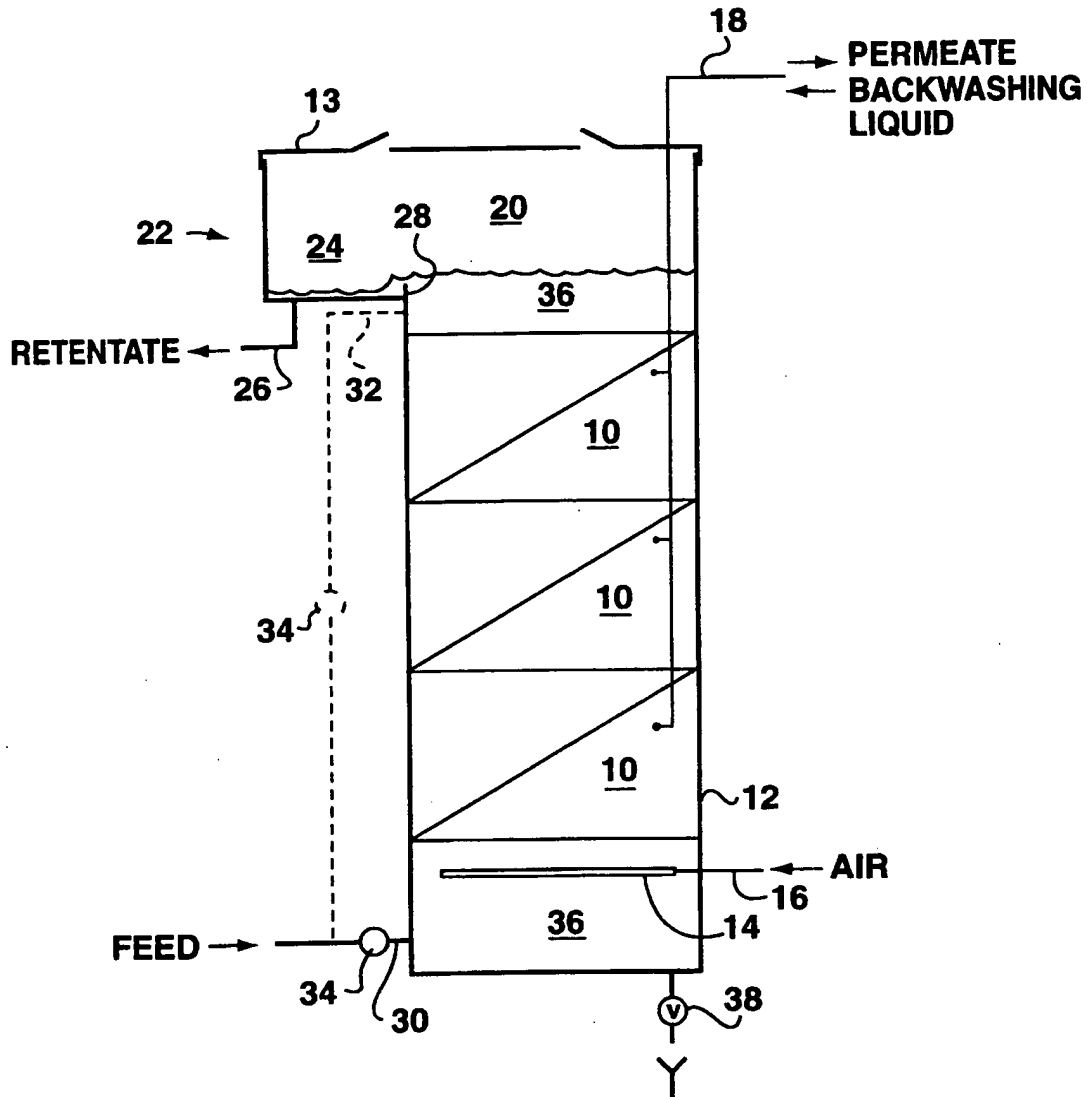

FIG. 2

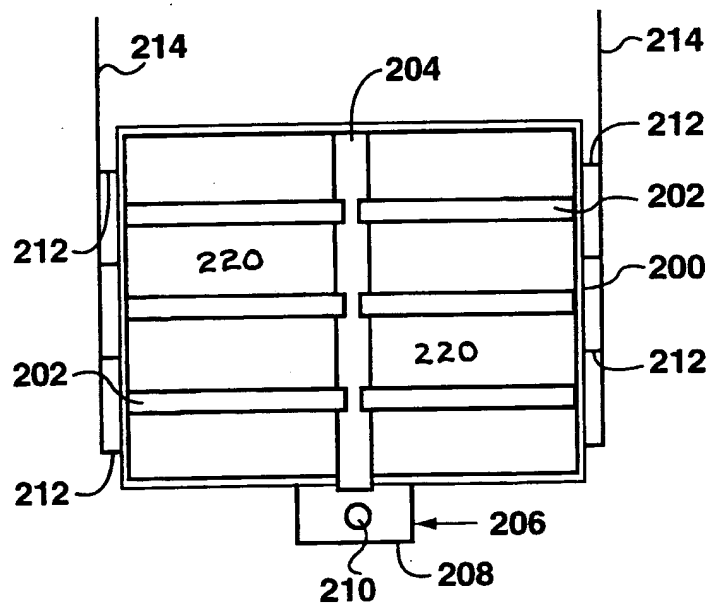

FIG. 3

INTERNATIONAL SEARCH REPORT

International Application No

PCT/CA 00/01354

A. CLASSIFICATION OF SUBJECT MATTER

IPC 7 B01D65/02 B01D65/06 B01D63/02 B01D63/04 C02F3/06

According to International Patent Classification (IPC) or to both national classification and IPC

B. FIELDS SEARCHED

Minimum documentation searched (classification system followed by classification symbols)

IPC 7 B01D C02F

Documentation searched other than minimum documentation to the extent that such documents are included in the fields searched

Electronic data base consulted during the international search (name of data base and, where practical, search terms used)

WPI Data, PAJ, EPO-Internal

C. DOCUMENTS CONSIDERED TO BE RELEVANT

Category *	Citation of document, with indication, where appropriate, of the relevant passages	Relevant to claim No.
A	PATENT ABSTRACTS OF JAPAN vol. 1997, no. 02, 28 February 1997 (1997-02-28) & JP 08 281082 A (KUBOTA CORP), 29 October 1996 (1996-10-29) abstract	1, 8, 19
A	PATENT ABSTRACTS OF JAPAN vol. 1999, no. 04, 30 April 1999 (1999-04-30) & JP 11 000534 A (KURITA WATER IND LTD), 6 January 1999 (1999-01-06) abstract	10-18
A	DE 296 20 426 U (PREUSSAG NOELL WASSESTECHNIK) 30 April 1997 (1997-04-30) claims; figures	10-18
	-/--	

Further documents are listed in the continuation of box C.

Patent family members are listed in annex.

* Special categories of cited documents:

A document defining the general state of the art which is not considered to be of particular relevance

E earlier document but published on or after the international filing date

L document which may throw doubts on priority claim(s) or which is cited to establish the publication date of another citation or other special reason (as specified)

O document referring to an oral disclosure, use, exhibition or other means

P document published prior to the international filing date but later than the priority date claimed

T later document published after the international filing date or priority date and not in conflict with the application but cited to understand the principle or theory underlying the invention

X document of particular relevance; the claimed invention cannot be considered novel or cannot be considered to involve an inventive step when the document is taken alone

Y document of particular relevance; the claimed invention cannot be considered to involve an inventive step when the document is combined with one or more other such documents, such combination being obvious to a person skilled in the art.

G document member of the same patent family

Date of the actual completion of the international search

2 March 2001

Date of mailing of the international search report

10/04/2001

Name and mailing address of the ISA

European Patent Office, P.B. 5818 Patentlaan 2
NL - 2280 HV Rijswijk
Tel. (+31-70) 340-2040. Tx. 31 651 epo nl,
Fax: (+31-70) 340-3016

Authorized officer

Cordero Alvarez, M

INTERNATIONAL SEARCH REPORT

Internat. Application No

PCT/CA 00/01354

C.(Continuation) DOCUMENTS CONSIDERED TO BE RELEVANT

Category *	Citation of document, with indication, where appropriate, of the relevant passages	Relevant to claim No.
A	PATENT ABSTRACTS OF JAPAN vol. 1997, no. 06, 30 June 1997 (1997-06-30) & JP 09 047762 A (TOTO LTD), 18 February 1997 (1997-02-18) abstract ---	1,6,7,9, 15,16,20
A	PATENT ABSTRACTS OF JAPAN vol. 1997, no. 12, 25 December 1997 (1997-12-25) & JP 09 220569 A (KUBOTA CORP), 26 August 1997 (1997-08-26) abstract -----	1

INTERNATIONAL SEARCH REPORT

Information on patent family members

International Application No

PCT/CA 00/01354

Patent document cited in search report	Publication date	Patent family member(s)	Publication date
JP 08281082 A	29-10-1996	NONE	
JP 11000534 A	06-01-1999	NONE	
DE 29620426 U	20-03-1997	NONE	
JP 09047762 A	18-02-1997	NONE	
JP 09220569 A	26-08-1997	NONE	